



## 2x4 In-Wall Tank & Carrier System K-18829

### Features

- Robust steel tube frame.
- Insulated tank to prevent sweating.
- Adjustable height allowing the bowl to be set anywhere from 15 inches to 23 inches from floor.
- Dual flush actuator offers a choice of 0.8 or 1.6 gallons per flush (gpf).
- Supply line not included.
- Can be used with K-6299 bowl and K-4177/K-8857/K-5413/K-75890/K-75891 flush actuator plates to create a complete package.

### Installation

- Durable steel frame carrier is installed on 2x4 studs behind the wall. See installation guide and installation video for more detailed information.

### Water Conservation & Rebates

- WaterSense® toilets meet strict EPA flushing guidelines, including using at least 20 percent less water than 1.6-gallon toilets.
- Eligible for consumer rebates in some municipalities.

### Required Accessories

K-4177 Flush Actuator Plate

or

K-6299 Wall-Hung Elongated Toilet Bowl

or

K-8857 Flush Actuator Plate

### Optional Accessories

K-7208

### Components

Product includes:

K-18829 2x4 In-Wall Tank & Carrier System



### Codes/Standards

ASME A112.6.2

ASME A112.19.14

### KOHLER® One-Year Limited Warranty

See website for detailed warranty information.

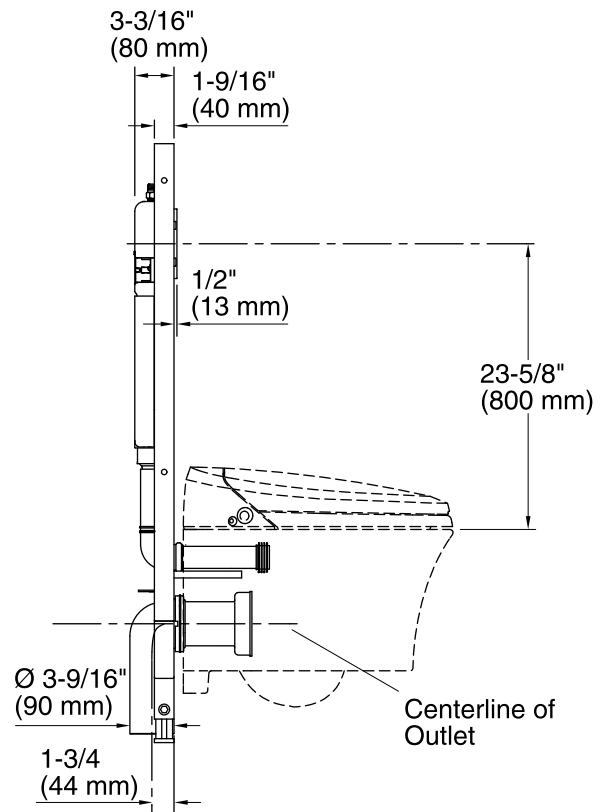
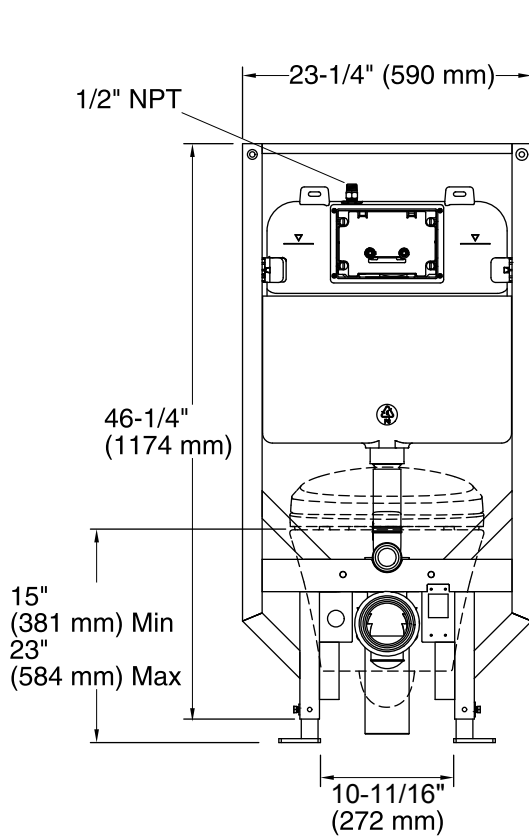

### Technical Information

All product dimensions are nominal.

Toilet type: In-wall, Wall-mount

Waste Outlet: Wall

Water Consumption

Full: 1.6 gpf (6 lpf)

Reduced: 0.8 gpf (3 lpf)

Rough-in: Wall-hung

### Fixture Supply Requirements

Max static pressure: 80 psi (551.6 kPa)

### Notes

Install this product according to the installation instructions.

Requires 2x4 or 2x6 stud construction.

Refer to manufacturer and local codes for flush valve requirements.

In-wall tank and carrier system install in wall opening 3-3/16" (80 mm) x 23-1/4" (519 mm) x 50" (1270 mm) minimum.